

PERFORMANCE
SUSPENSION
USER GUIDE

Thank you for purchasing the Rev9™ performance suspension product. We aim to manufacture the best product with strict quality procedures to satisfy all the requirements from our customers.

Please read and understand all the instructions before proceeding to installation. Our company does not take any responsibility for loss, accident, damage or death caused by misuse, improper installation of the product, using parts not supplied by our company or retrofitting without our written consent.

Basic safety precautions should always be followed when using and installing the suspension system to reduce the risk of damage or property loss. Please carry out the proper installation instructions and use them as suggested.

ENSURE FITMENT OF THIS PRODUCT FOR YOUR APPLICATION,

- Review the model / part number of this suspension kit and compare it with the year, make and model of your vehicle.
- **DO NOT INSTALL ANY PARTS IF YOU ARE UNSURE.** It is the customer's responsibility to match and ensure that this part is the correct model for your vehicle before proceeding.
- We do not accept any returns or warranty claims on items that have already been installed due to buyer negligence such as ordering parts incorrectly or incorrect use.
- If you find the product to be defective, missing parts, or damaged during transit, please contact your original place of purchase for assistance within 24 hours of receiving the product.
- Updates or redesigns of products are subject to change without any notice.

BEFORE INSTALLATION:

- Please READ the contents of this guide carefully and completely before proceeding with any installation.
- All products should be installed by a valid licensed professional with prior experience in aftermarket suspension parts.

- Please use the product in accordance with your local law regulations. We are not responsible/liable for the illegal use and installment of this product.

INSTALLATION:

- Certain applications may require OE top mount during installation, new factory top mounts are recommended. If using OE top mounts from your existing factory strut, please make sure they are in good working condition. Due to pressurized parts, take **EXTREME CARE** when removing the factory top mount from the strut assembly.
- If this product is used in conjunction with additional modified parts, Godspeed Project will not be held responsible/liable for any damages/injuries that may occur to the installer, vehicle or parts.
- **PISTON ROD NOTICE:** Please handle with care. Any damage to the piston rod may cause an oil leak. Dirt, sand, mud, and other debris may cause damages to the piston rod. Periodic cleaning is recommended to prolong the life of the shock absorber.
- **POSITION & DIRECTION:** Please use discretion when installing. Determine which strut assembly is left and right side by comparing to the original factory struts prior to mounting them on the vehicle.
- The included spanner wrenches are used to help adjusting length of strut easier. Spanner wrench are not meant to use to tighten spring perch, lower mount or lock rings. To ensure all the lock rings are securely fastened, please use the mallet and flat-head screwdriver to tighten the lock rings.
- Make sure all brake lines and/or ABS lines are secured. On certain applications that do not have a mounting bracket, zip-ties may be substituted as a temporary measure.
- Finally, check all bolts and nuts to make sure they are tightened properly (33-35 ft./lbs of torque for shock tower nuts). See OEM Torque specs for OEM bolts to the knuckle or lower control arm.

POST INSTALLATION:

- **IMPORTANT:** Please check all lock rings, bolts, and nuts on a regular basis to ensure they are securely fastened.
- **PRIOR** any adjustment, please ensure that the shock body is free of dirt, sand, mud, or any debris to avoid and prevent thread stripping or seizing.
- **ALWAYS** do periodically check on parts and cleaning.

SPANNER WRENCH

- Spanner wrenches are meant to be used as tool kit to help turning lock rings, spring perches and lower mounts easier, not meant to be use as tightening tool.
- To secure tighten lock rings, please use the mallet and flat-head screw-driver to tighten lock rings, spring perches and lower mounts.
- ALWAYS periodic check for tightness as part of car maintenance routine.
- DO NOT turn the rings without clean dirt or debris off the threaded shock body first.

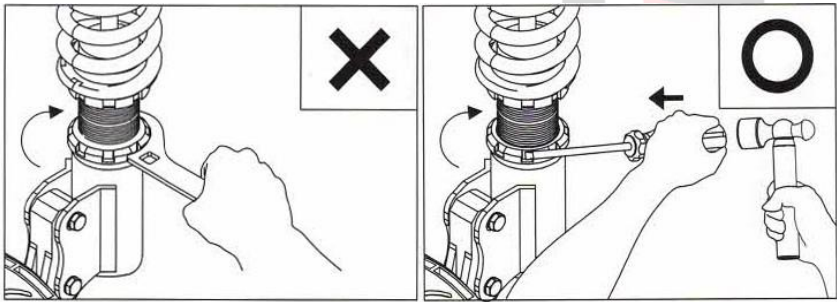

DAMPING FORCE ADJUSTMENT

- Damping adjuster controls the shock piston stroke speed when it returns to its original position.
- Clockwise direction is HARD (slow) / Counter-Clockwise direction is SOFT (fast).
- General Tip, keep left and right at the same damping level but front and rear do not need to be the same setting and should be set according to user preference.
- Always start by turning the knob all the way to HARD then work your way back.



PILLOW BALL CAMBER PLATE

- Most applications include "PILLOW BALL CAMBER PLATE UPPER MOUNT." Make sure the camber plate is installed in the proper clock direction. (see illustrations)
- Loosen the four (4) Allen bolts to adjust camber angle. Do Not OVER-TORQUE. (Max 12 ft/lb)
- Always make sure all the bolts are properly tightened as a final check. Please do regular periodic checks as part of car maintenance.
- Certain vehicles may require to cut open sheet metal in order to access the camber plate.

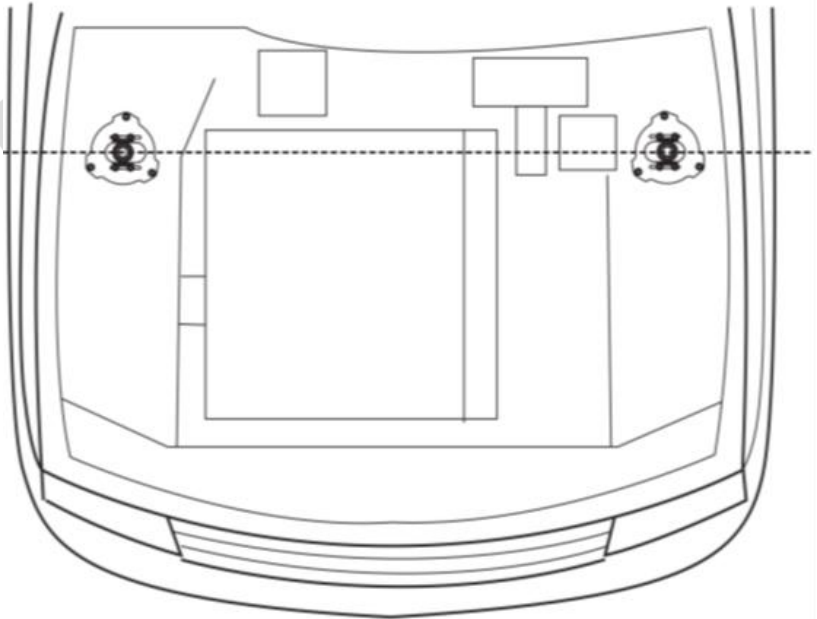
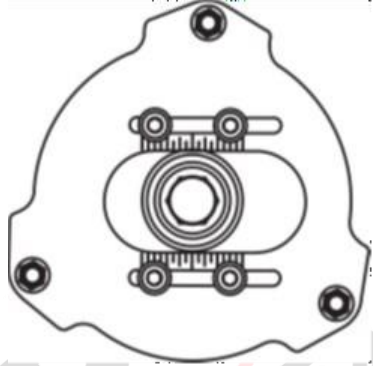

FOR OE TOP MOUNT

- Make sure to lower the spring prior installing the OE (Originally Equipped) top mount taken from your original strut. ("A" in the illustration)
- Lowering the spring helps avoid tension push back from the spring during installation of the top mount.
- After the OE top mount is seated and secured properly, make sure to adjust spring preload. ("A" In the illustration)
- Different car models has different installation sequences of suspension parts. *ALWAYS make sure everything is seated and secured properly prior to being installed on the vehicle.*

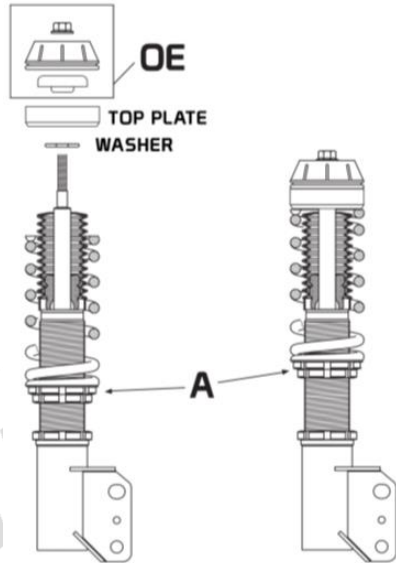

SPRING PRELOAD

- Spring preload helps hold the whole strut assembly together and keep the shock piston straight while it works. If the car is lowered by dropping the spring seat position will result in bend piston shock when it extends more than spring length.
- Spring preload should not be more than 10mm of spring free standing length. (See diagram)
- "A" - Spring seat and lock ring holds the spring against the top mount or radial bearing plate.
- Spring preload limits spring travel distance hence tighter the preload results in shorter travel distance of the spring will have stiffer ride quality.

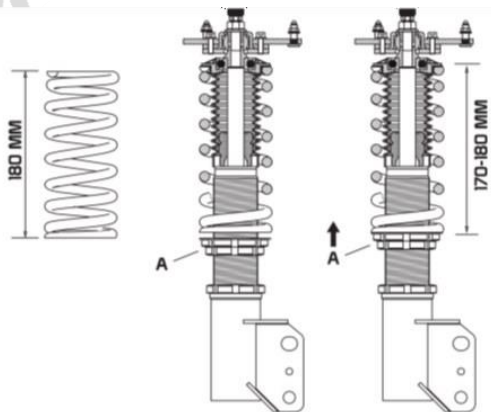

RIDE HEIGHT

- Our coilovers kit are full-length type that ride height is determined by overall length of the strut, unless it's independent type.
- ALWAYS start at the max length then adjust according to your preference. Out of the box are usually compacted for transportation purposes.
- Due to weight distribution, not all corners of the vehicle will have exact length measurements. Please adjust accordingly.
- NEVER over extend strut assembly. These are lowering kit that at max length will still be at least 30 MM lowered from factory ride height.

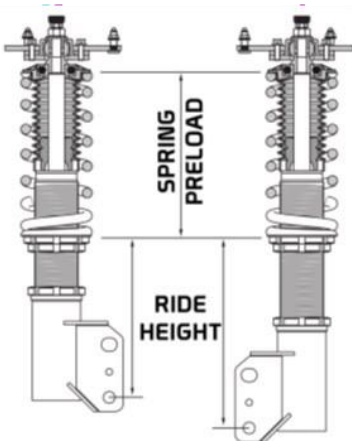

MAGPHERSON TYPE

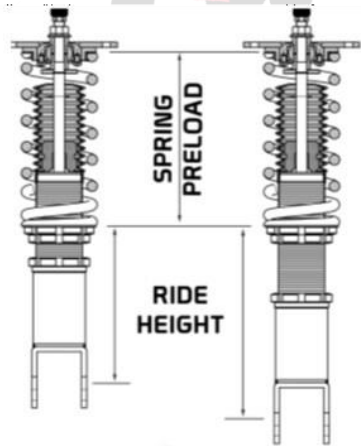

WISHBONE TYPE

- *MacPherson Type* — minimum 50 mm (1-3/4 inch) threaded body inside the lower mount. Also make sure the thread body has enough clearance from the axle when shorten.
- *Wishbone Type* — minimum 30 mm (1-1/4 inch) threaded body inside the lower mount.

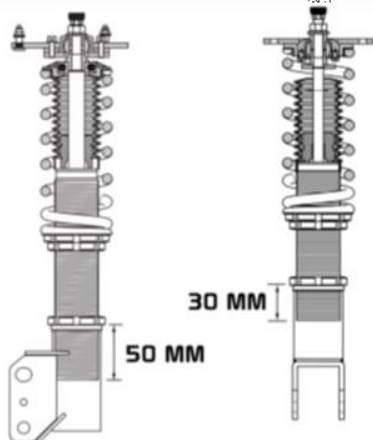

MacPherson Type

Wishbone Type

INDEPENDENT (Separate) TYPE:

- RIDE HEIGHT is determined by overall height of the spring and its adjuster perch.

PRELOAD PROCEDURES:

- 1) Setting desired ride height by adjusting overall length of the spring and its perch.
- 2) Use a floor jack with support to raise the control arm that spring sits on so that spring has tension. DO NOT exceed over 10mm than spring length.
- 3) Mount top of the shock onto the vehicle then adjust the lower mount of the shock so that extended length is just 10 mm longer than the mounting point.
- 4) Now process to secure the lower mount onto the factory mounting point.

CAUTION: Overall length of strut being too short or too long can damage the shock and cause noises in the future.

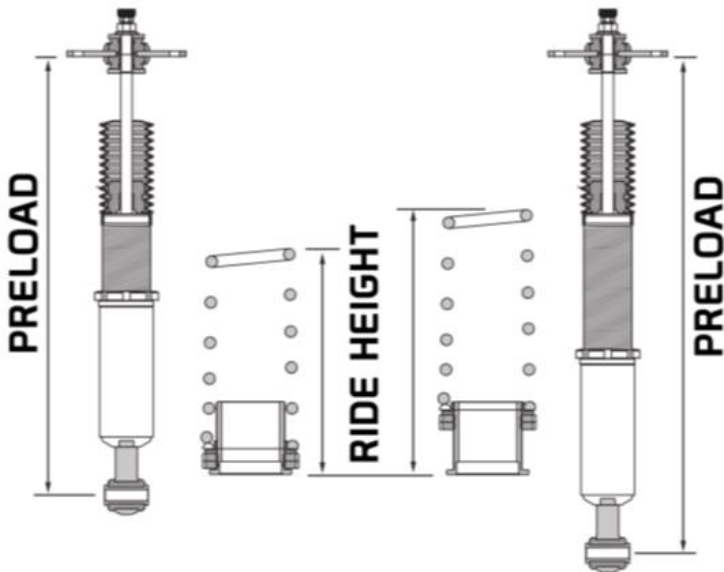

INDEPENDENT TYPE (SEPARATE)

SWAY BAR END LINKS

- Use included adjustable end links for installation, if there are no end links included means You will need to use your OE end links.
- DO NOT over extend the end links, do not go over 30mm (1-1/4 inch) each end, which can cause premature failure.
- Please check the condition of the factory end link prior reinstall them, replace then if necessary.
- When end links are too long or short will result in noises when vehicle is turning.

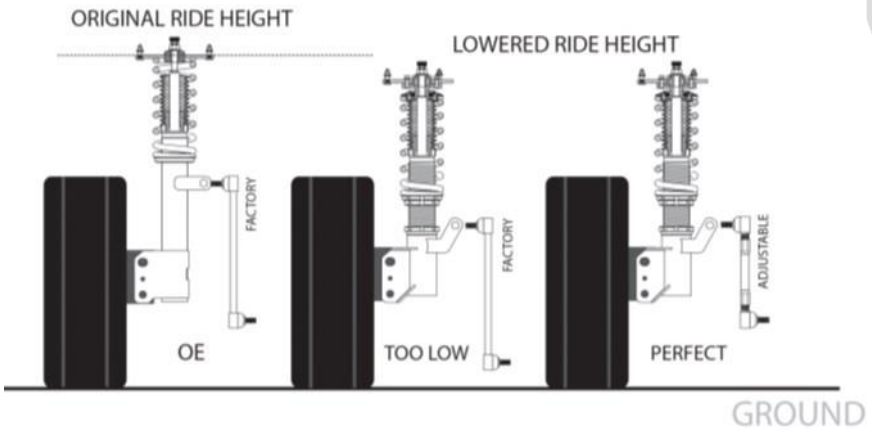

F.A.Q.

Q: Why do some kits include sway bar end links?

A: End links are only included when brackets needed to be relocate in order to have room to lower the car.

Q: What's the torque spec for the allen bolts to adjust the camber?

A: Recommended torque spec for those bolts are 12 ft/lb.

Q: My setup is very bouncy, how can I check for issues?

A: Check spring preload if your setup is true coilover style. As for the separate type setup, please make sure the shock is lengthened to match spring and adjuster overall length, also make sure to remove the factory springs.

Q: My coilovers are making noise when going over a bump, how do I check for the issue?

A: Check the spring preload to see if spring is secured from moving up and down freely. If that don't solve the issue, check the top center nut is tighten.

Q: My coilovers are making noise during turning, how do I check for the issue?

A: 2 common issues are spring preload is too tight causing spring bind or sway bar end links length