

**131BW003N1**

**BMW 8 SERIES 840i RWD  
G16**

**ASP**

ADJUSTABLE SPRING PERCH

**BC**



Thank you for purchasing the BC Racing A.S.P.  
Please read this instruction guide carefully before proceeding with install.

BC Part Number	131BW003N1
Vehicle	BMW 8 SERIES 840i RWD
Model/Chassis	G16
Year	2018+
Min. Ride Height from OEM	FRONT -35mm
	REAR -40mm
TIRE SIZE FRONT	245/35/20
TIRE SIZE REAR	275/30/20

▲ All vehicle lowering data is for reference only and may vary depending on individual vehicle conditions.

### **Disclaimer**

The BC Racing ASP is designed and intended to lower a vehicle's ride height. The use of this product on public roadways may not meet local, state, or federal regulations. Installation and use of this product may affect the vehicle's original manufacturer's warranty. It is the consumer's responsibility to meet and comply with federal, state, or local government regulations and/or policies prior to operating the vehicle on public roadways.







### **ATTENTION!!**

Removal of OEM components from damper assemblies and installation of this product may only be undertaken by trained technical personnel with ASE certification.





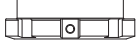

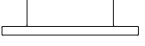
Incorrect installation/adjustment can damage OEM Dampers or other OEM components, which we are not able to supply. Installers shall be responsible for any damage due to incorrect installation or adjustment.

## Parts List

### FRONT

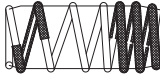
SA11-2019		DUST COVER	2
SA11-0030-18		BUMPSTOP	2
1-SPS-25509-A2		SPRING	2
SA05-1104		RUBBER SPRING SEAT	2
SG07-1102		LOCKING RING	2
SG07-2211		SPRING PERCH	2
SA15-6004		M6 SET SCREW	2
SA05-1102		BOTTOM RUBBER PAD	2

### REAR

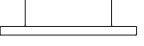
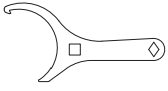
SA11-2019		DUST COVER	2
SA11-0030-14		BUMPSTOP	2
1-SPS-28006-A1		SPRING	2
SA05-1104		RUBBER SPRING SEAT	2
SG07-1102		LOCKING RING	2
SG07-2211		SPRING PERCH	2
SA15-6004		M6 SET SCREW	2
SA05-1102		BOTTOM RUBBER PAD	2
SG12-0065		SPANNER	1

## Before Installation



### CAUTION

- This product was designed and developed for specific vehicle models and should only be installed on the intended application. Ensure you received the correct items for your vehicle before attempting installation.
- No part of this instruction may be reproduced or transmitted in any form or by any means, electronic or mechanical, including photocopying, recording, or by any information storage and retrieval system, without express written permission from Taiwan Bor-Chuann Enterprise Co., Ltd.
- **This product may only be installed by trained technical personnel with ASE certification.**
- Do not use impact wrenches to install or remove damper/shock absorber hardware.
- Installation and removal of suspension components including dampers and springs must be in accordance with the original manufacturer's specifications. Please refer to the factory service manual if available.
- BC (Taiwan Bor-Chuann Enterprise Co., Ltd) is not liable for any damages and/or failures caused by the use of components not supplied by BC (Taiwan Bor-Chuann Enterprise Co., Ltd).
- Incorrect installation or adjustment can cause noise and/or damage to the product, which will not be covered by warranty.

## ARROW INDICATION

- INSTRUCTION
- BC SUPPLIED ASP PARTS
- OEM PARTS

## Installation FRONT/REAR

# 1

Remove the OEM damper cap, and it will need to be placed back later.

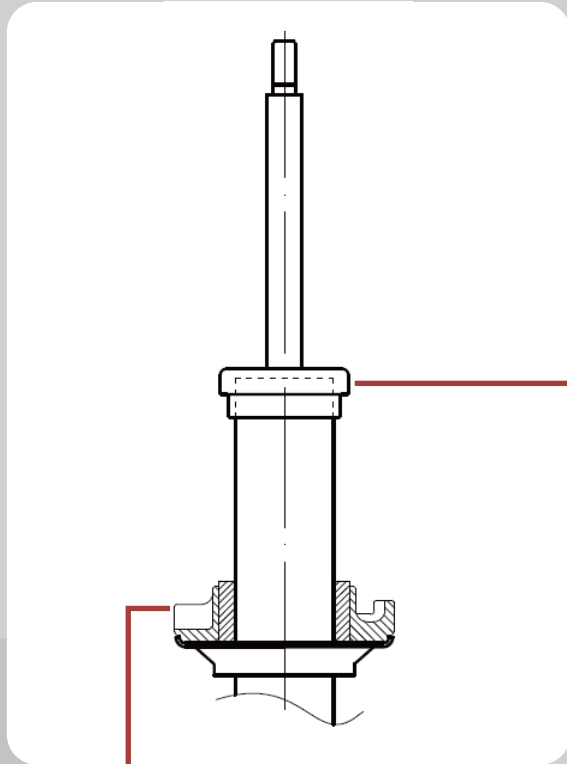

# 2

Remove the OEM lower spring seat which will be replaced with the BC supplied ASP adjustable spring perch.

# 3

Slide the parts on the left over the damper in order. Don't forget to tighten up the screw after height adjustment.

BC Insulator

Spring Perch

Bottom Rubber Pad

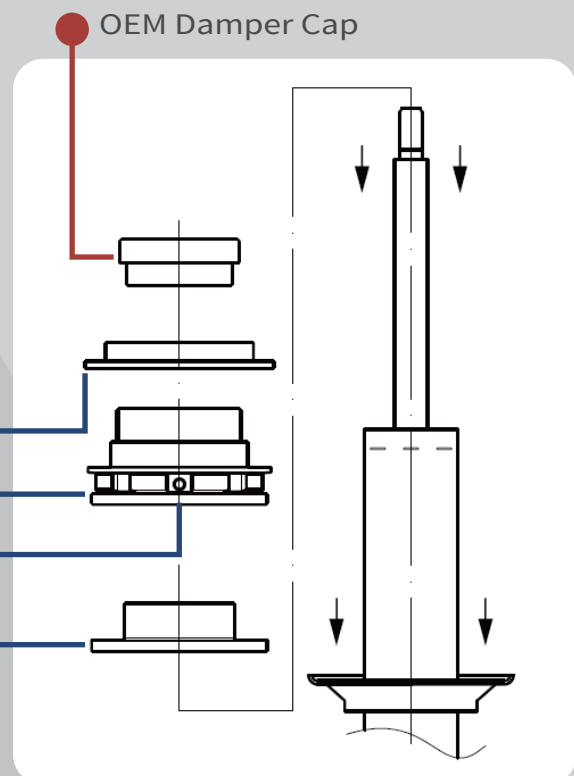

## 4

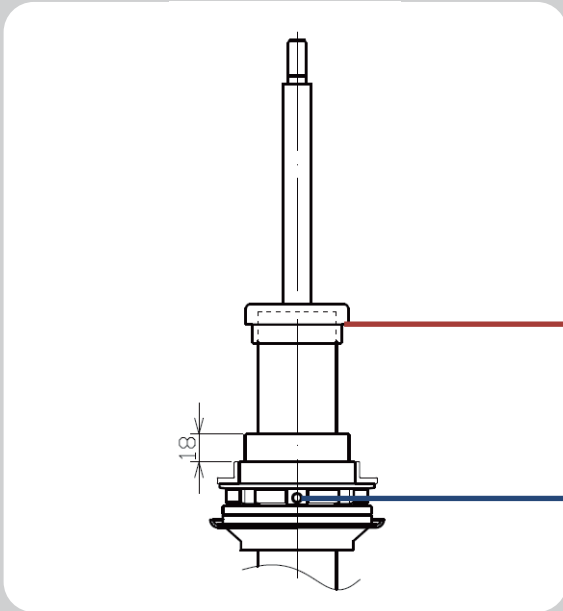

This is how it now looks. Reinstall the OEM damper cap and tighten the M6 set screw inside the locking ring.

OEM Damper Cap

M6 Set Screw

## 5

Slide the BC bump stop, BC dust cover and 255mm spring over the front damper. (280mm spring for the rear damper)

BC Spring 255mm FRONT  
(BC Spring 280mm REAR)

BC Dust Cover

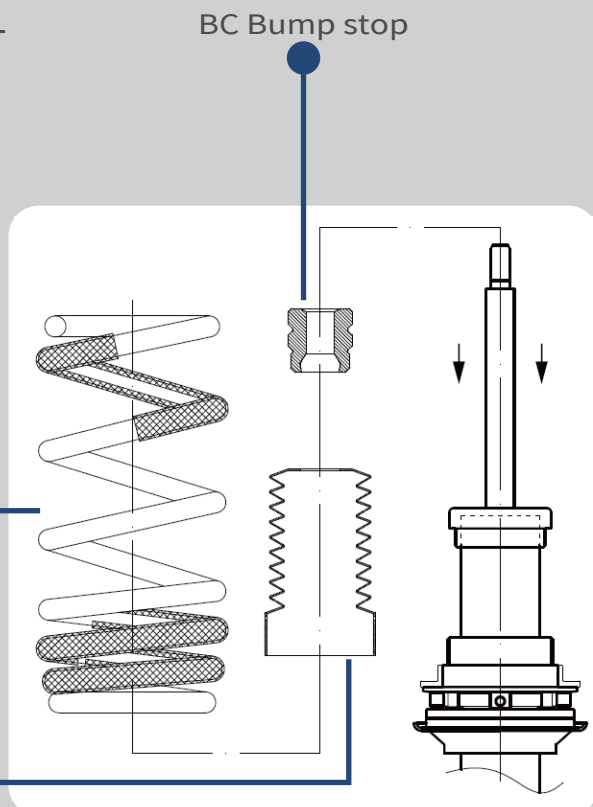

## 6

Reinstall the OEM top mount.

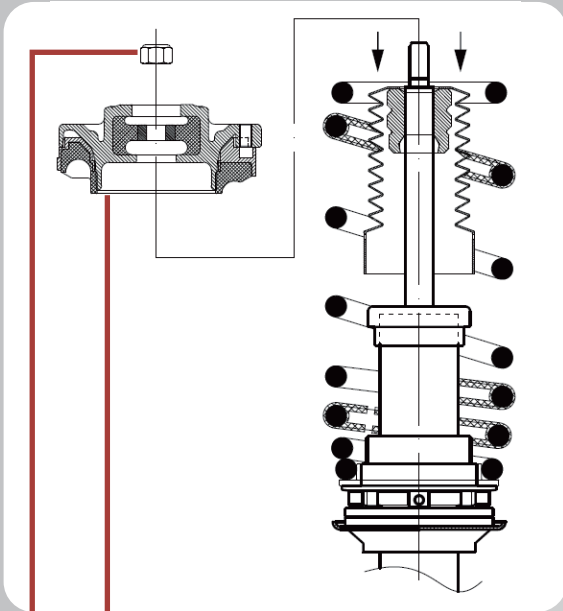

OEM Top Mount

OEM Top Nut

## 7

Tighten up the front OEM M12 top nut with 50Nm of torque.  
(Rear M10 top nut with 25Nm)

Front OEM M12 Top Nut

(Torque 50Nm)

Rear OEM M10 Top Nut

(Torque 25Nm)

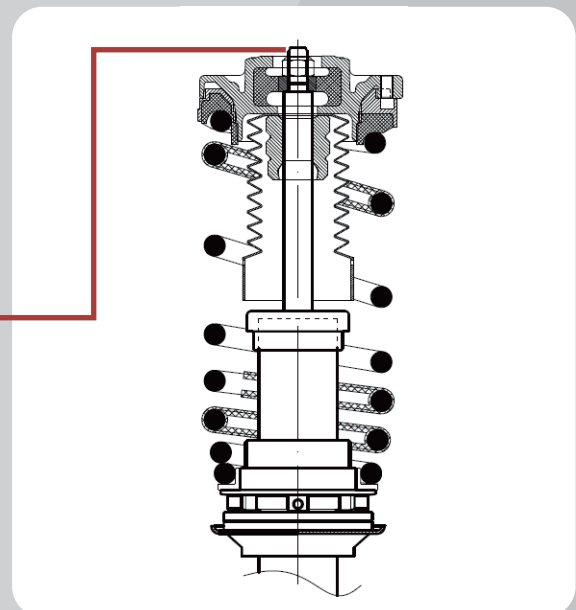



- Do not over tighten damper top nuts. All hardware should be tightened in accordance with the recommended torque values specified in the vehicle manufacturer's manual.

## Adjustment

- Do not over tighten the spring as this will compress spring and cause rate shifting.
- Always clean dirt and debris from threads with pressurized air and/or brake cleaner. It is recommended to grease adjuster threads before performing ride height adjustments to prevent locking rings from seizing.

## After Installation

- Make sure all hardware that was removed during installation are properly tightened.
- Ensure the set screw on each locking ring is tightened.
- A full vehicle alignment is highly recommended after installation, as it greatly influences the vehicle's handling characteristics and tire wear.
- Perform regular periodic checks on all hardware and locking rings.

## Technical Support

- Please keep the original purchase invoice and warranty card for future service requests.
- Lowering your vehicle will change chassis suspension geometry. This can lead OEM components such as control arms, to generate noise. Relative age and condition of the surrounding suspension components may exacerbate noise production, commonly referred to NVH (noise, vibration, harshness).
- Please contact your local distributor for more information concerning technical support or advice concerning the product.





**ASP**

ADJUSTABLE SPRING PERCH

---

**BC**



 [bc@bcec.com.tw](mailto:bc@bcec.com.tw)

 [www.bcec.com.tw](http://www.bcec.com.tw)